

# MV-ID6120M-00C-NNG

12 MP Smart Code Reader



## Introduction

With built-in code reading algorithm, MV-ID6120M-00C-NNG smart code reader can read different types of 1-dimensional code and 2-dimensional code with reading speed up to 60 codes/sec. It adopts deep learning algorithm to process image with good robustness, and can recognize various poor printing quality barcodes.

## Key Feature

- Adopts built-in code reading algorithm and deep learning algorithm with good robustness to read different codes.
- Adopts CMOS sensor to acquire image data and provide high-quality image.
- Supports various trigger modes and image acquisition modes.
- Adopts multiple IO interfaces for inputting and outputting signals.
- Supports RS-232 serial port and indicators displaying device status.

## Available Model

MV-ID6120M-00C-NNG

## Applicable Industry

Logistics code reading, factory automation, etc.

## Accessories

- Lens: KF series FA lens
- Light source: MV-LB-200-200-20WL

## Dimension

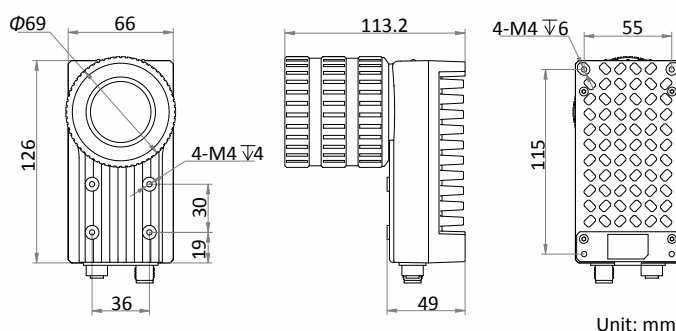

## Specification

<b>Model</b>	<b>MV-ID6120M-00C-NNG</b>
<b>Performance</b>	
<b>Symbologies</b>	1-dimensional codes: Code 39, Code 128, Code 93, ITF25, CodaBar, UPC/EAN 2-dimensional codes: QR, Data Matrix
<b>Max. frame rate</b>	20 fps @4096 × 3000
<b>Max. reading speed</b>	60 codes/sec
<b>Sensor type</b>	CMOS, rolling shutter
<b>Pixel size</b>	1.85 μm x 1.85 μm
<b>Sensor size</b>	1/1.7"
<b>Resolution</b>	4096 × 3000
<b>Exposure time</b>	16 μs to 1 sec
<b>Gain</b>	0 dB to 40 dB
<b>Mono/color</b>	Mono
<b>Communication protocol</b>	SmartSDK, TCP Client, TCP Server, Serial, FTP, HTTP
<b>Electrical feature</b>	
<b>Data interface</b>	Gigabit Ethernet interface
<b>Digital I/O</b>	12-pin M12 connector provides power and I/O, including opto-isolated input (LineIn 0/1/2) x 3, opto-isolated output (LineOut 0/1/2) x 3, and RS-232 x 1.
<b>Power supply</b>	12 VDC to 24 VDC
<b>Max. power consumption</b>	< 12 W@24 VDC
<b>Mechanical</b>	
<b>Lens mount</b>	C-mount
<b>Light source</b>	Not included
<b>Lens cap</b>	Included
<b>Dimension</b>	126 mm x 66 mm x 113.2 mm (5.0" x 2.6" x 4.5")
<b>Weight</b>	Approx. 750 g (1.7 lb.)
<b>Ingress protection</b>	IP67 ( under proper installation of waterproof lens cap)
<b>Temperature</b>	Working temperature: 0 °C to 50 °C (32 °F to 122 °F) Storage temperature: -30 °C to 70 °C (-22 °F to 158 °F)
<b>Humidity</b>	20% to 95% RH, without condensation
<b>General</b>	
<b>Client software</b>	IDMVS
<b>Certification</b>	CE, FCC, RoHS