

MV-ID6200M-00C-NNG

20 MP 1" CMOS Smart Code Reader



Introduction

With built-in code reading algorithm, MV-ID6200M-00C-NNG smart code reader can read different types of 1-dimensional code and 2-dimensional code with reading speed up to 60 codes/sec. It adopts deep learning algorithm to process image with good robustness, and can recognize various poor printing quality codes.

Key Feature

- Provides 20 MP resolution to cover a larger field of view.
- Adopts deep learning algorithm with good robustness to recognize various poor printing quality codes.
- Supports recognition of multiple codes in the field of view.
- Supports gigabit Ethernet transmission to output images.
- Supports networking of multiple devices via code reading platform.
- Ingress protection (IP) 67.

Available Model

MV-ID6200M-00C-NNG

Applicable Industry

Delivery logistics, warehouse logitics, etc.

Accessories

- Lens: KF series FA lens
- Light source: MV-LB-270-140-4030WL-A

Dimension

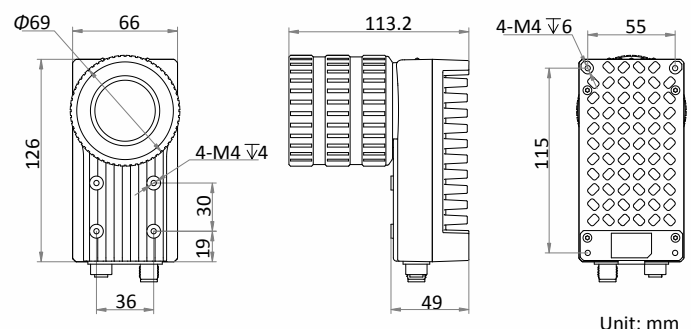

Specification

Model	MV-ID6200M-00C-NNG
Performance	
Symbologies	1-dimensional codes: Code 39, Code 128, Code 93, ITF 25, CodaBar, EAN 8, EAN 13, UPCA, UPCE, ITF 14 2-dimensional codes: QR Code, Data Matrix
Max. frame rate	20 fps
Max. reading speed	60 codes/sec
Sensor type	CMOS, rolling shutter
Pixel size	2.4 μm \times 2.4 μm
Sensor size	1"
Resolution	5440 \times 3648
Exposure time	16 μs to 0.5 sec
Gain	0 dB to 40 dB
Mono/color	Mono
Communication protocol	SmartSDK, TCP Client, TCP Server, Serial, FTP
Electrical feature	
Data interface	Gigabit Ethernet
Digital I/O	12-pin M12 connector provides power and I/O, including opto-isolated input (LineIn 0/1/2) \times 3, opto-isolated output (LineOut 3/4/5) \times 3, and RS-232 \times 1.
Power supply	12 VDC to 24 VDC
Max. power consumption	12 W@24 VDC
Mechanical	
Lens mount	C-mount
Light source	Not included
Lens cap	Included
Dimension	126 mm \times 66 mm \times 113.2 mm (5.0" \times 2.6" \times 4.5")
Weight	Approx. 750 g (1.7 lb.)
Ingress protection	IP67 (under proper installation of waterproof lens cap)
Temperature	Working temperature: 0 $^{\circ}\text{C}$ to 50 $^{\circ}\text{C}$ (32 $^{\circ}\text{F}$ to 122 $^{\circ}\text{F}$) Storage temperature: -30 $^{\circ}\text{C}$ to 70 $^{\circ}\text{C}$ (-22 $^{\circ}\text{F}$ to 158 $^{\circ}\text{F}$)
Humidity	20% to 95% RH, non-condensing
General	
Client software	IDMVS
Certification	CE, FCC, RoHS